

EQUALITY

VS.

EQUITY

# Advancing Teaching and Learning Through Equity and Excellence

Regional Professional Learning  
2019





PROJECT 1



VISION:

Equity and excellence in teaching and learning.

# Learning Agreements (Workshop Norms)

- 1. Be honest about your current reality.**
- 2. Actively listen and participate.**
- 3. Voice and respond to concerns positively and non-judgmentally.**
- 4. Love the idea first to embrace its possibilities.**
- 5. Slow down to think, reflect, and puzzle about things.**
- 6. Hold each other accountable for agreed upon norms.**



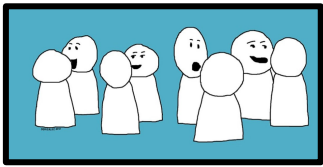

Talk about your favorite season and why it is your favorite.



What three words describe you best?



What is the best thing that happened to you this week?



Who is your role model?



Who was your favorite teacher and why?



What was your favorite subject in school?

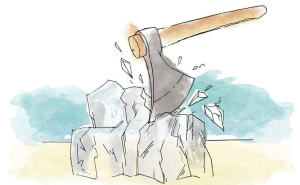

# SKETCH NOTING

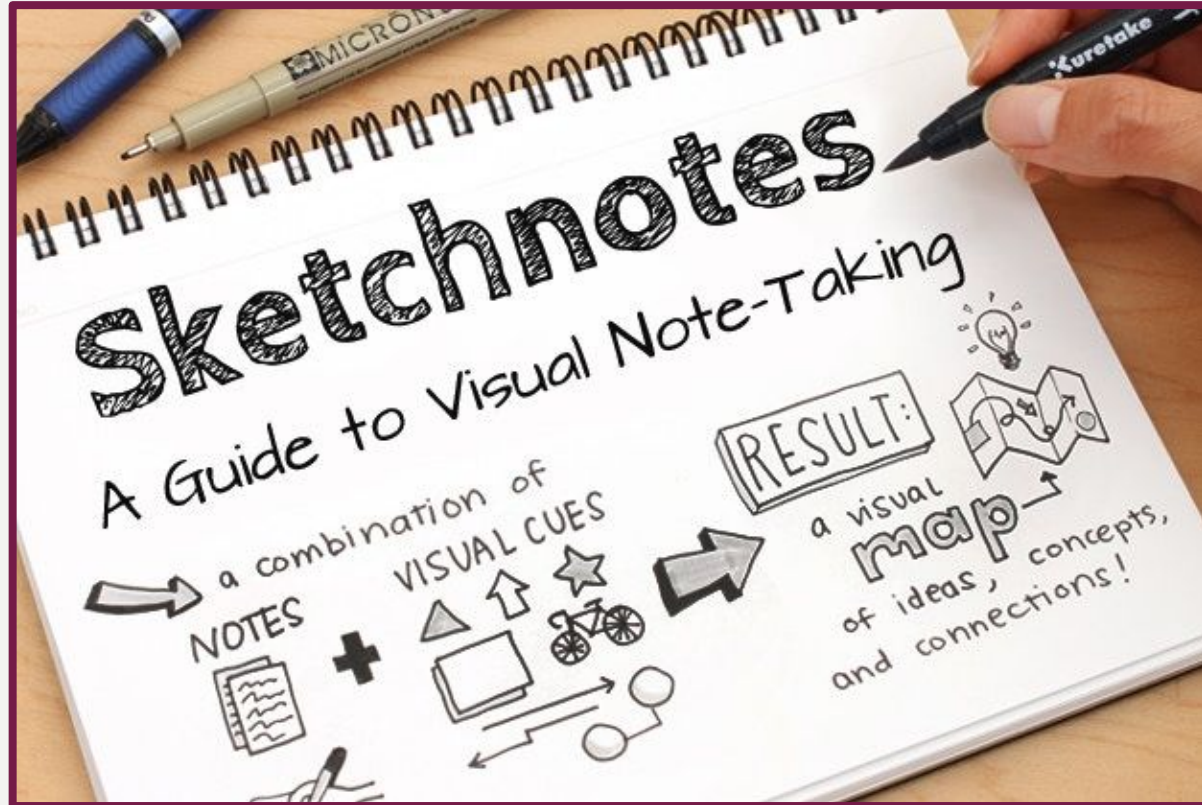

(3:02)

<https://www.youtube.com/watch?v=gY9KdRfNN9w>



As we go through today, you can create a Sketchnote for all of the concepts/strategies about which we talk.

**WHY SKETCHNOTES...**  
@Envora TANMAY VORA QASPIRE.COM

SIMPLIFIES THE **COMPLEX**

**visual METAPHORS** allow brain to fill **gaps**

**ENABLES CONNECTION and synthesis OF IDEAS**

**raises ATTENTION and ENGAGEMENT**

**organizes and SUMMARIZES insights**

**A TOOL FOR IMMERSIVE LEARNING**

**eases CLARITY and comprehension**

**HELPS IN SENSE MAKING**

**QUICK GRASP and memory BETTER RETENTION**

**EASY sharing & COMMUNICATION**

TEXT 10% PICTURES 35% TEXT + PICTURES 65%

JOHN MEDINA "BRAIN RULES"



Or, take notes  
on the blank  
die template.

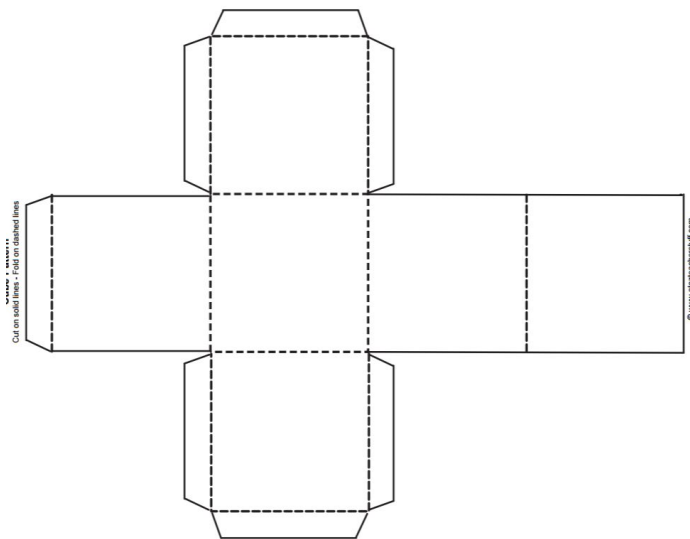

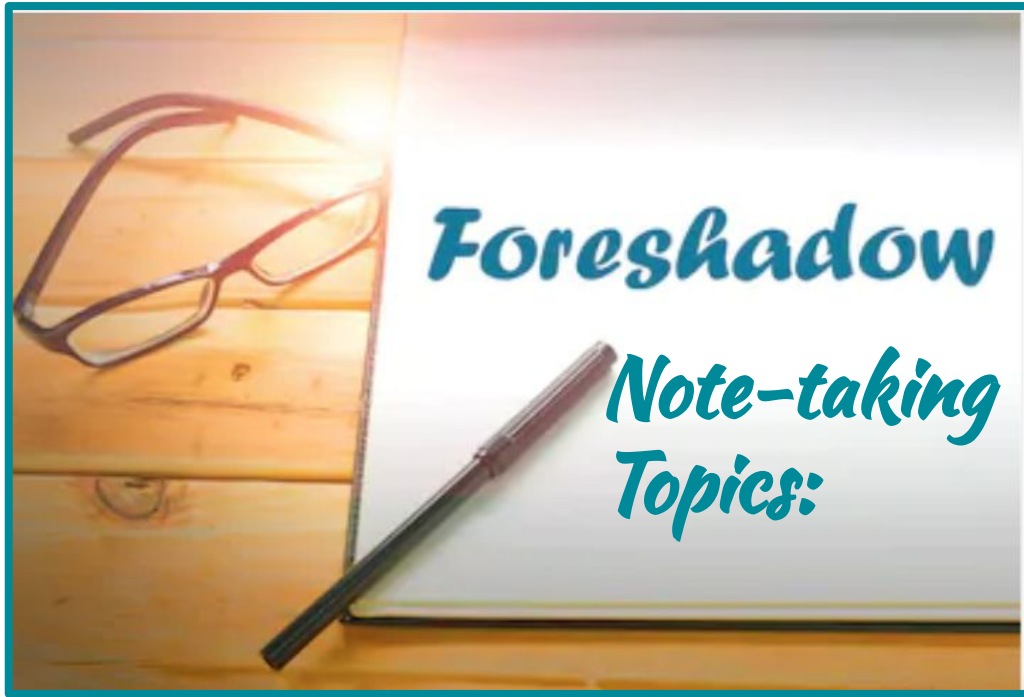

- *Curriculum*
- *Equity*
- *Protocols*
- *Academic Conversations*
- *Takeaways*
- *Ideas*



# What is curriculum?

1. Write your definition of curriculum on a post-it.
2. Share your definitions at your table.
3. Synthesize all ideas to create one definition for your table.
4. Choose someone to share the definition.



# What is curriculum?

*Our definition for today:*

*The specific learning standards, lessons, assignments (formative assessments), and materials used to organize and teach a particular course.*

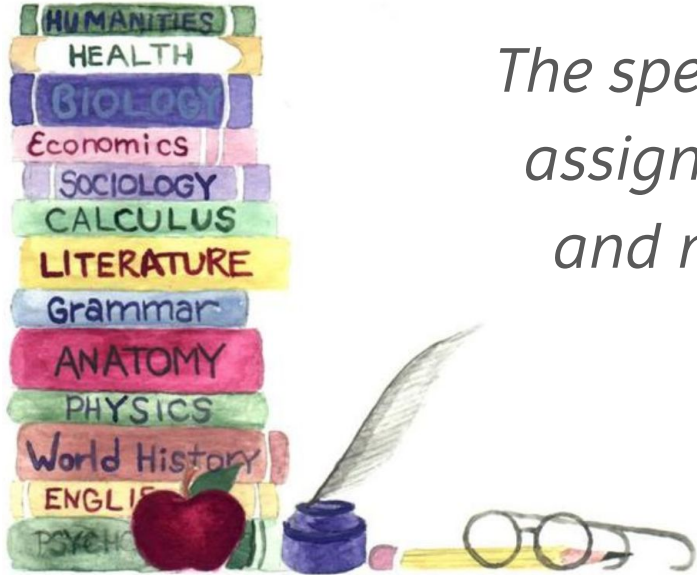

# What is curriculum?

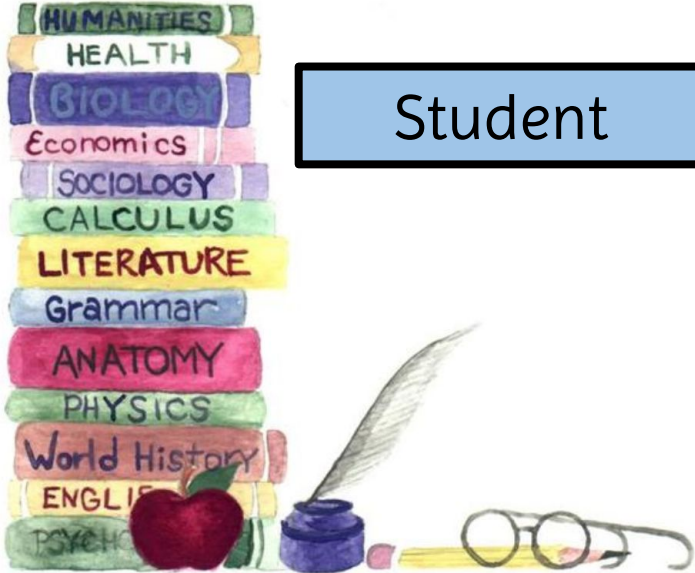
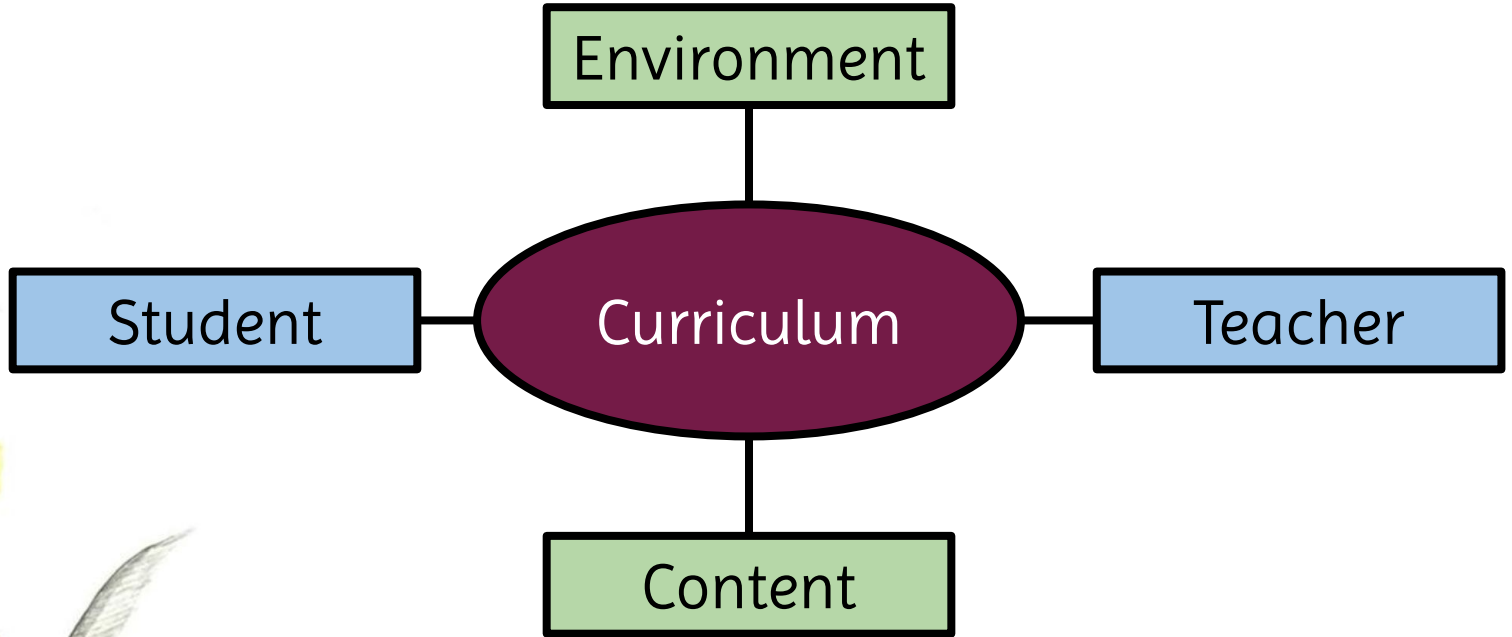

# Curriculum according to Joseph Schwab



## Content & Pedagogy

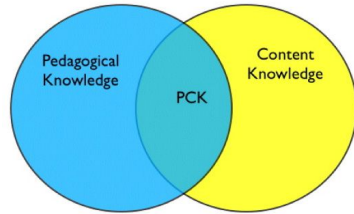

## Students



## Teacher



## Context / Environment

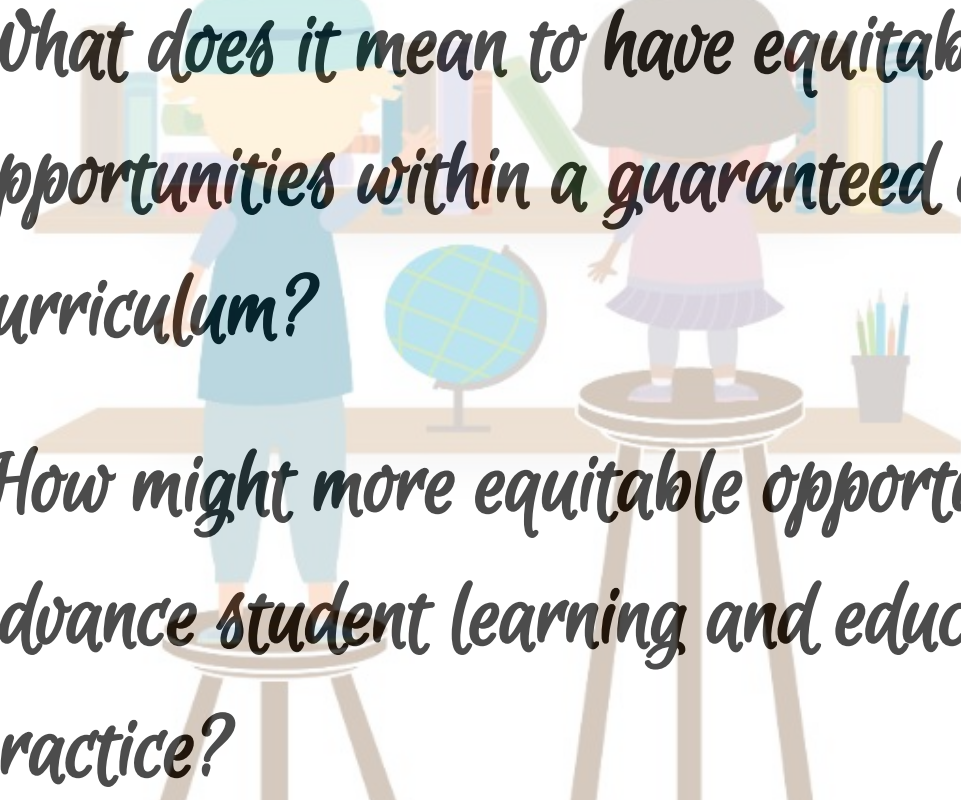

# EQUITY

- *What does it mean to have equitable opportunities within a guaranteed and viable curriculum?*
  - *How might more equitable opportunities advance student learning and educator practice?*
- 
- An illustration of two children sitting at a desk. The child on the left is taller and has blonde hair, wearing a blue shirt and pants. The child on the right is shorter and has brown hair, wearing a pink shirt and purple skirt. On the desk are a globe, a pencil holder with colored pencils, and a stack of books. The background is a light blue wall with a shelf of books.

What are some tools and resources to help us advance equity and excellence in teaching and learning?





# Tool # 1: Connected Action Roadmap

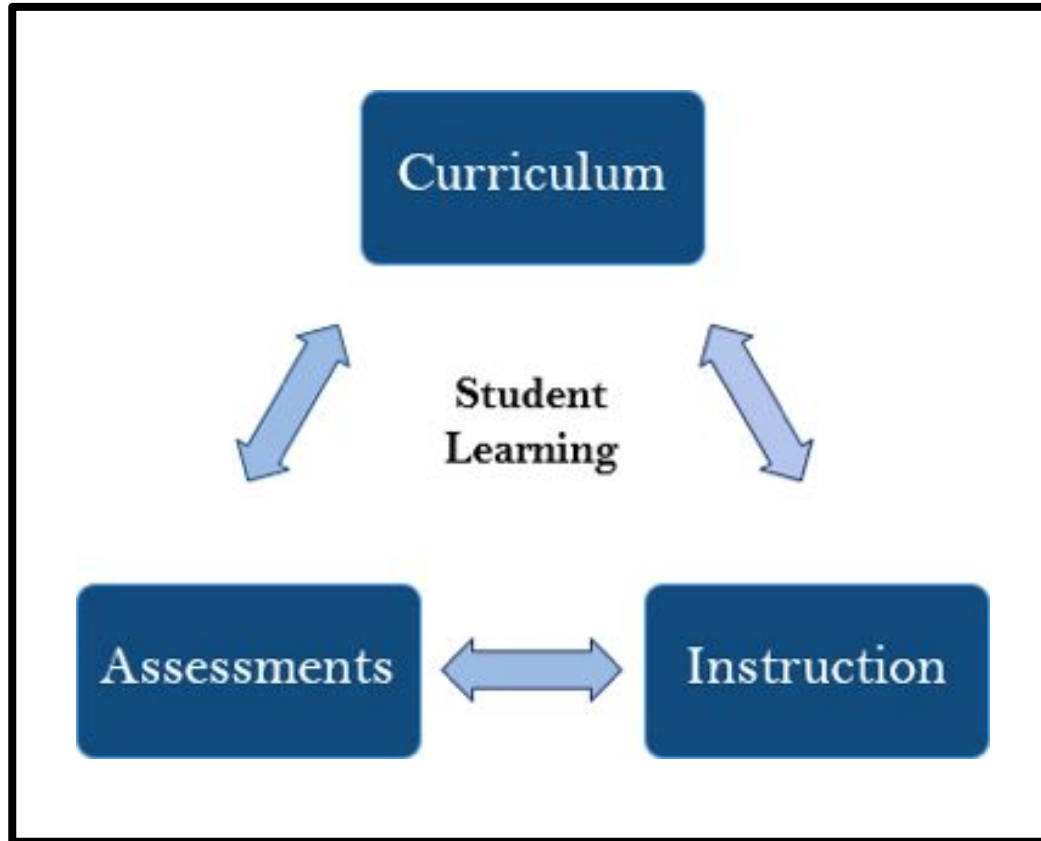

# Tool # 1: Standards-based Instruction Through the CAR Model Process

**Connected Action  
Roadmap:**  
An Aligned and  
Coherent Process for  
School Improvement

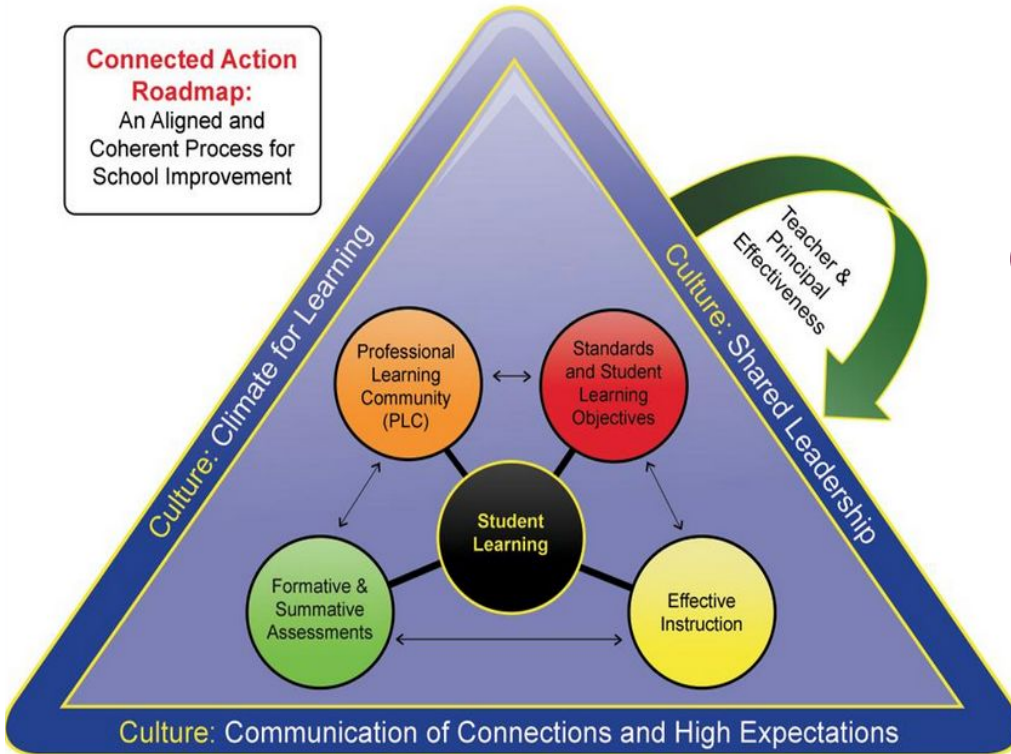

CAR: a systemic approach to

- teaching
- learning
- leading

---

---

# Let's Talk: Excellence and Equity for All Learners

---



---

Stella Cohen  
Terri Cooney  
Erin Cutillo

# Today's Agenda

- **Academic Conversations:**

- Building The Foundation

- **Excellence and Equity in Mathematics Instruction**

- Math Workshop: How do we address the needs of all learners?
- How is academic conversation involved?

- **Mathematical Discourse**

- Planning for Productive Math Discussions
- Conferring in Math

# **Academic Conversations: Building the Foundation for Equity and Excellence**

# Sheltered English Instruction Models

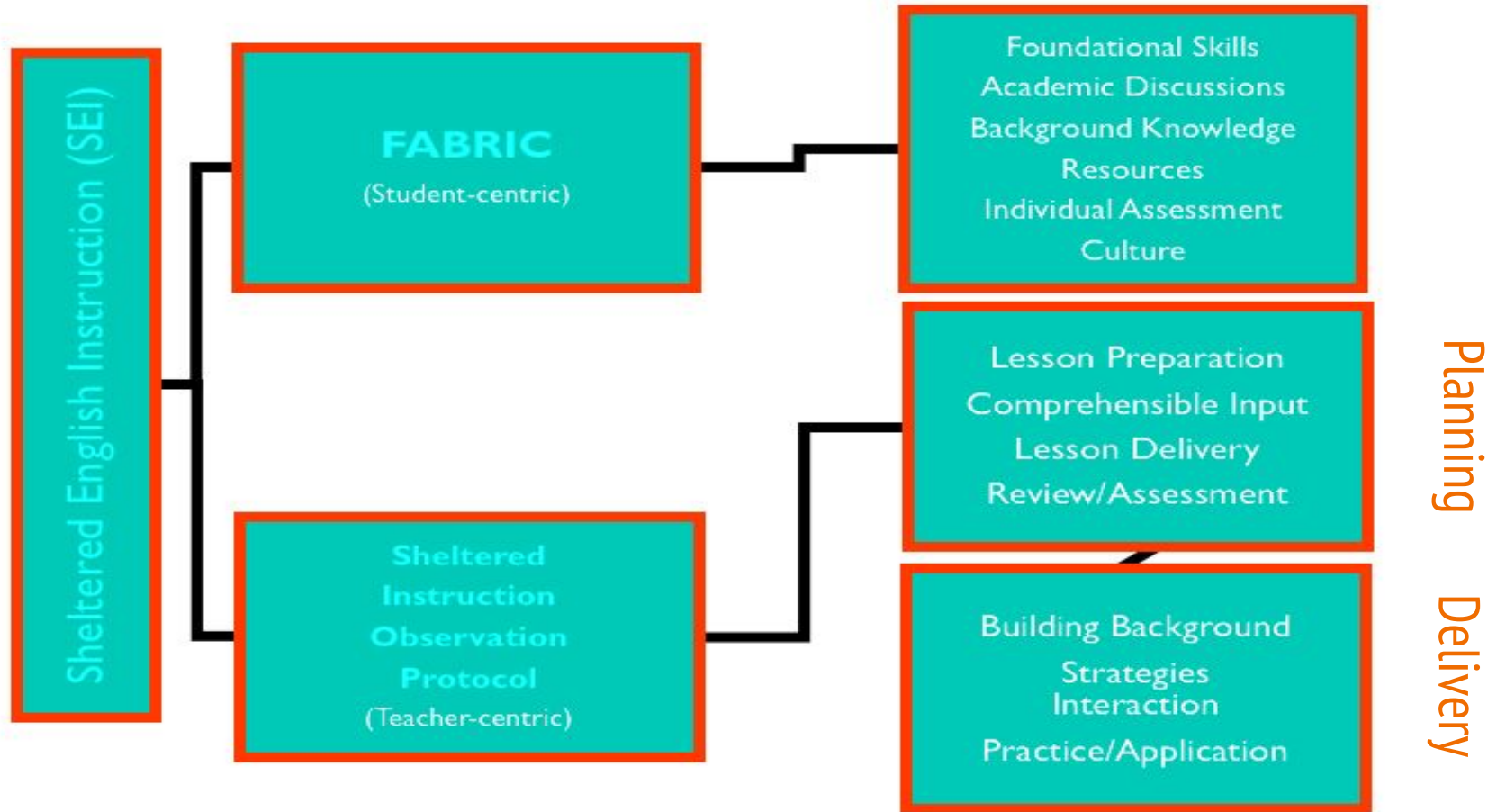



# Reasons to Converse in School

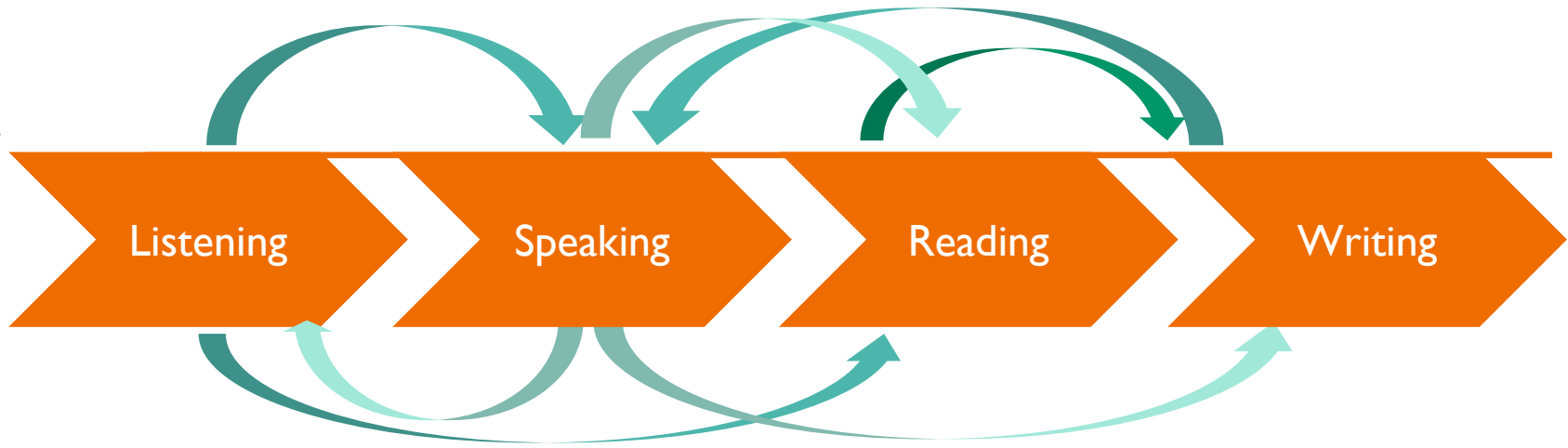

## According to Jeff Zwiers:

- Conversation supports development of the academic language, vocabulary, literacy skills and helps students develop communication skills.
- Conversation builds critical thinking skills and content understanding.
- Conversation helps with cultivating connections and relationships.
- Conversation can help support and push thinking.

# Conversations in your Classroom

## Think Write Pair Share



- About the prompt
- Your:
  - Thoughts
  - Opinions
  - Conclusions

**Think**

**Write**

- Down your thoughts
- Make notes to capture your ideas.

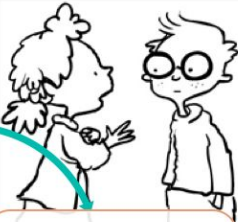

- Find a partner
- Share your thinking
- Clarify your confusion

**Pair**

**Share**

- With the class what you learned
- Write down what's discussed, evidences, examples

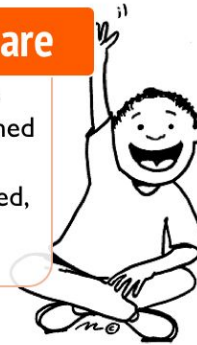

## Guiding Questions

- When do you typically use conversations or turn and talks in your classroom?
- Why do you use conversations or turn and talks in your classroom?
- What do you typically observe during conversations or turn and talks?
- What are some of the challenges that your students experience when having conversations?

- As I reflect upon my use of turn and talks I think about.....
- What are your thoughts about turns and talks?



**Partner A**

- What you shared was interesting because
- For me turn and talks are \_\_\_
- Can you tell me more about how you ..?



**Partner B**

# Introduction

## Academic Conversations

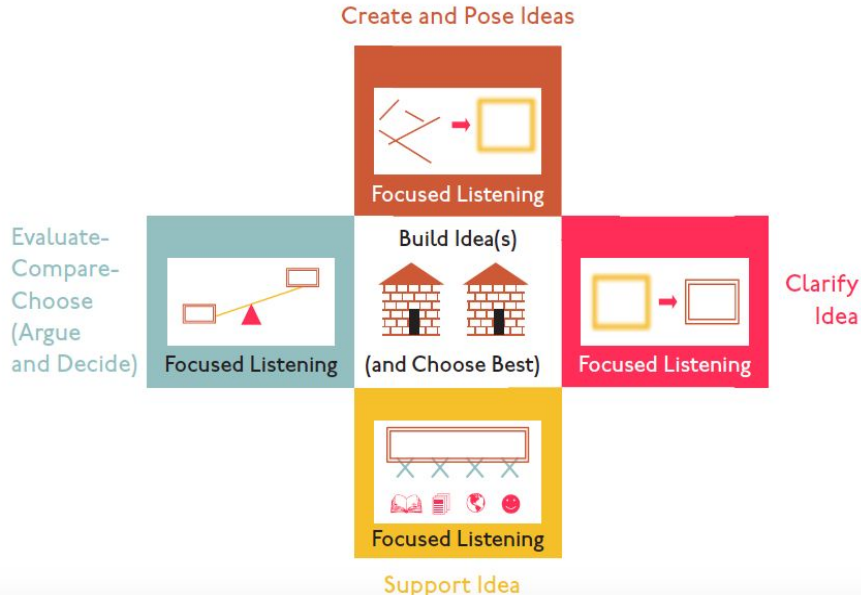

- Sustained and purposeful conversations about school topics
- Back-and-forth dialogue in which students focus on a topic and explore it by creating and posing ideas, clarifying ideas, supporting ideas, or evaluating ideas.

Image from *K-3 Guide to Academic Conversations: Practices, Scaffolds and Activities* by Jeff Zwiers and Sara Hamerla

# Step 1: Building a Conversation Culture

Establishing & Practicing  
Conversational Norms

Some ELLs might shy away from conversations because they might not be familiar with effective conversational behaviors/norms or cultural differences may create a challenge.

# Examples of Conversation Norms

- We take turns when we talk and share air time
- We listen to each other
- We share our own ideas and explain them
- We maintain eye contact with each other during a conversation
- We respect one another's ideas even if they are different
- We respectfully disagree and try to see the other view
- We let others finish explaining their ideas without interrupting
- We maintain attentive posture and use appropriate gesturing
- We nod our head to show understanding

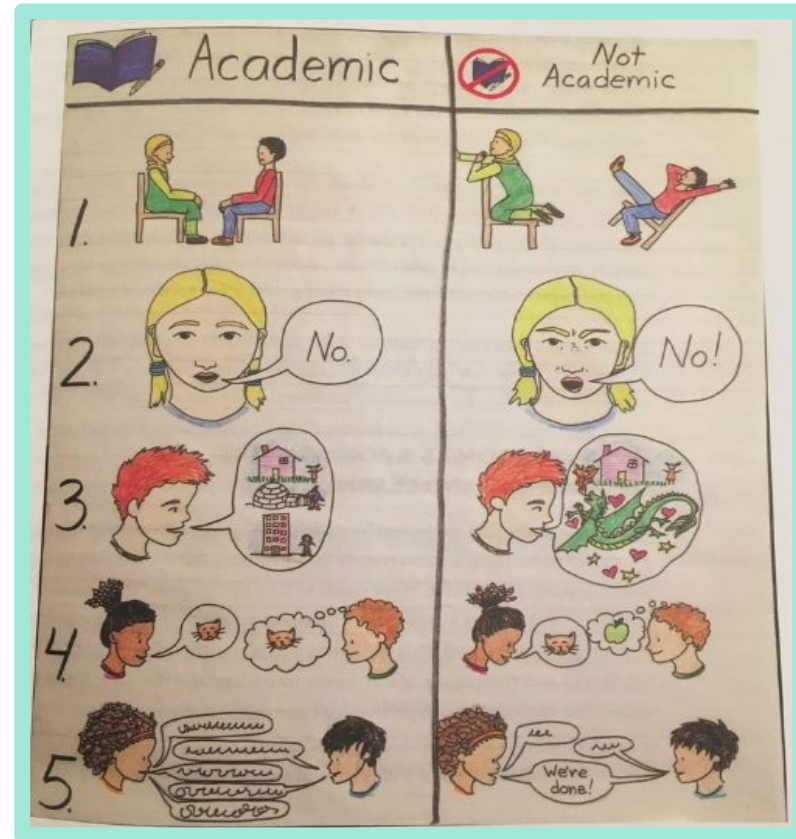



# Tools to Help Introduce & Practice Norms in K-2

## Active Listening and Responding

• Quiet Body



• Eyes Looking



• Listening and Thinking



• Responding



So, what I hear  
you say is...



I agree with your  
answer because...

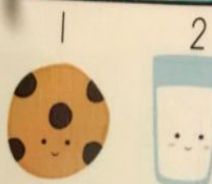

I disagree with  
your answer because...

Take turns 

Actively listen 

Look at partner 

Knee to knee 

## Whole Body Listening

Brain is thinking  
about what is being  
said

ears are  
listening

eyes are  
looking

mouth is  
quiet

hands are  
still

feet are  
still

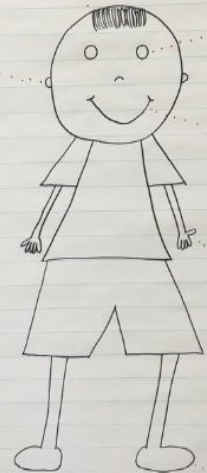

# Step 2: Listening Skills Unpacked

## Active Listening: Physical Indicators of Listening



Smile



Nod



Make Eye Contact

## Focused Listening: Cognitive Indicators of Listening

During and After Listening to My Partner:

Am I understanding what my partner is saying?  
Can I summarize it in one sentence?



Does what my partner is saying help to support and build up  
the current idea? Does it argue against the current idea?



Does what my partner is saying help to clarify the current idea?



## Listening Talk Moves: Listening Lingo

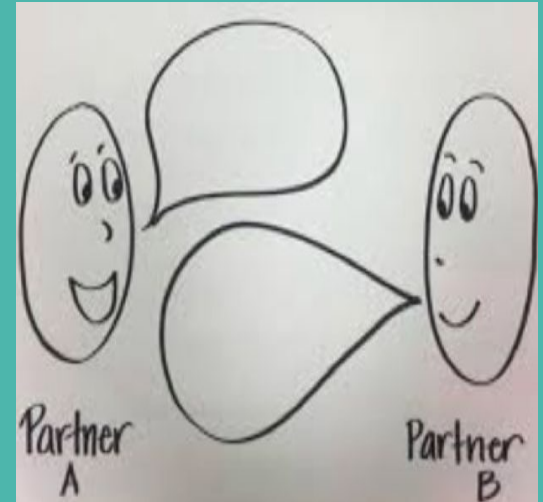

# WHY Unpack Listening Skills

## Active Listening- Physical Indicators of Listening

### Why?

1. Create positive feelings and contribute to feelings of safety and trust
2. Lets the speaker know you are listening

## Focused Listening- Cognitive Indicators of Listening

### Why?

1. Guides students through the steps of how to understand in order to respond.

## Listening Talk Moves – Listening Lingo

“Oh really. “ Wow!” “ Interesting! ”, “Uh huh”, ”Hmm..”

Tell me more about \_\_\_\_\_

I never thought or/ heard of this before

I have a question about \_\_\_\_\_

# Classroom Application: Listening Skills Tools

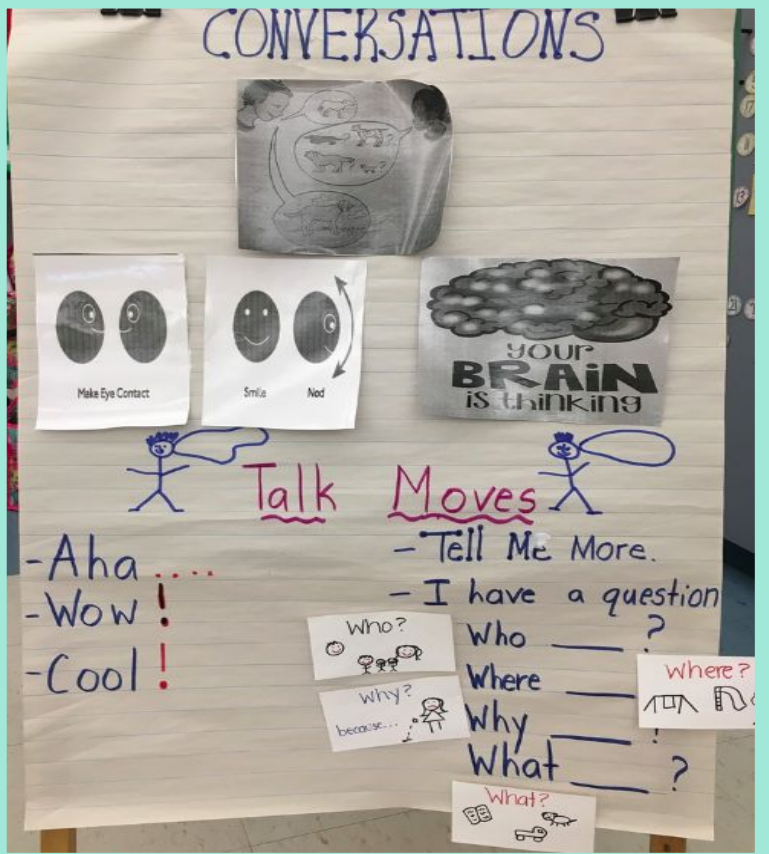

Images from Mrs. Saracino's and Ms. D'Onofrio's classrooms

# Step 3:

## Introduce and Practice Conversation Skills

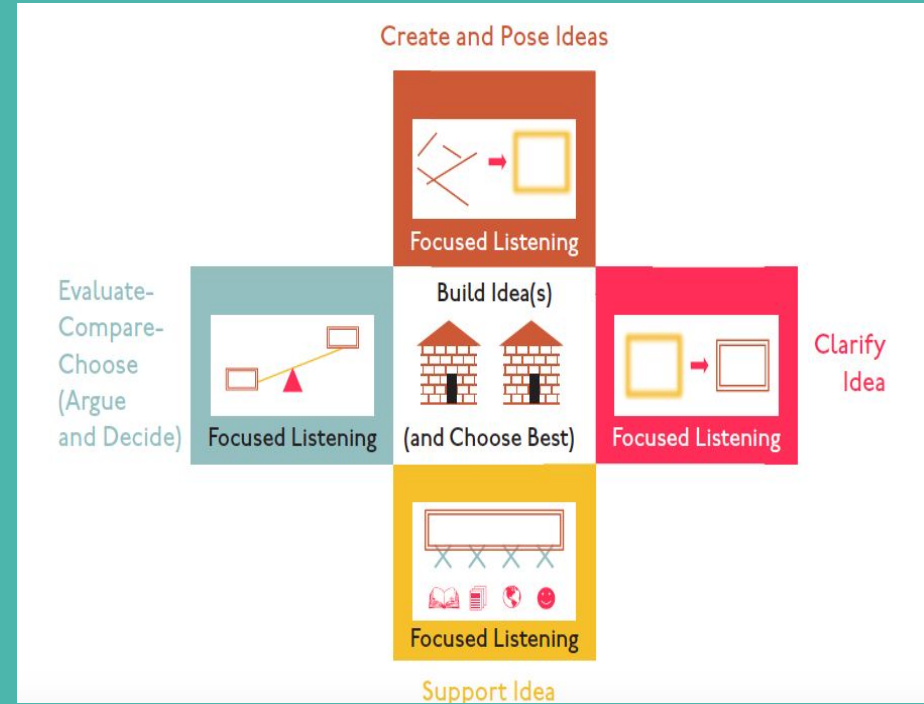

Images from *K-3 Guide to Academic Conversations: Practices, Scaffolds and Activities* by Jeff Zwiers and Sara Hamerla

# Skill 1: Create and Pose Ideas

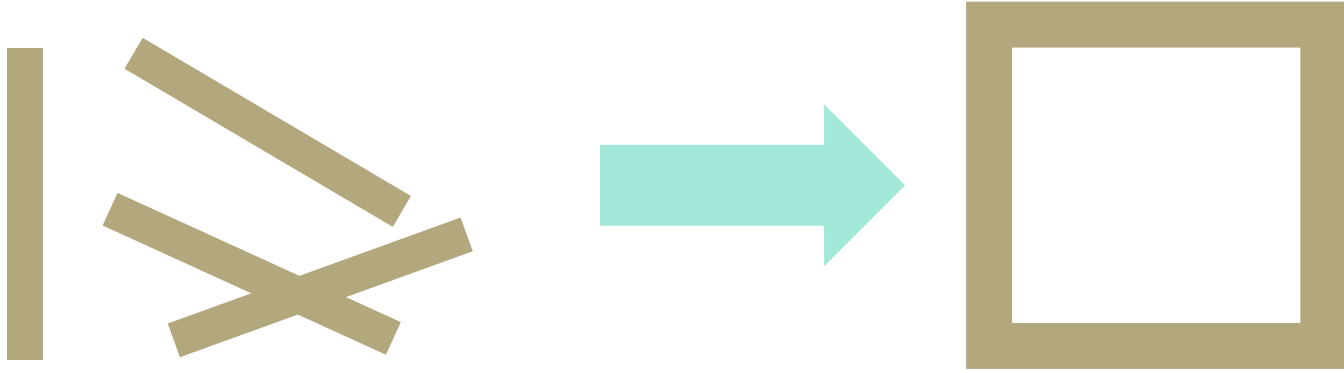

State an idea that solves a problem, finds a pattern, or gives an opinion.

## Question

What is your idea?

What does it remind you of?

## Responses

One idea is...

That reminds me of...



# Skill 2: Clarify Ideas

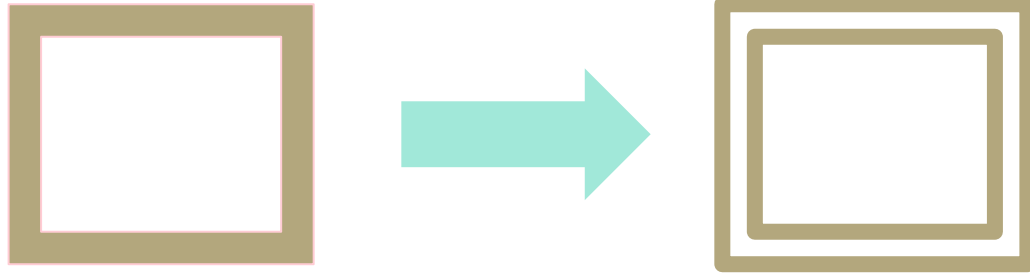

Make sure you both have the same understanding of the idea (be on the “same page”). You and your partner have a clear idea to build up.

## Question

Can you elaborate on...?

What do you mean by....?

What's your definition of...?

## Responses

In other words, you are saying that...

What I mean by...is...

# Skill 3: Support Ideas with Examples, Evidence, and Reasons



X



X



X



X

Support your idea with examples from the text, from other texts, from the world and from your life.

## Question

- Can you give an example from the book?
- ...from your life?
- ...from other books we have read?
- ...from the world?
- How does that example support the idea?

## Responses

- In the book it says...
- I also learned...
- This is important because...

# Conversation Skills Tools:

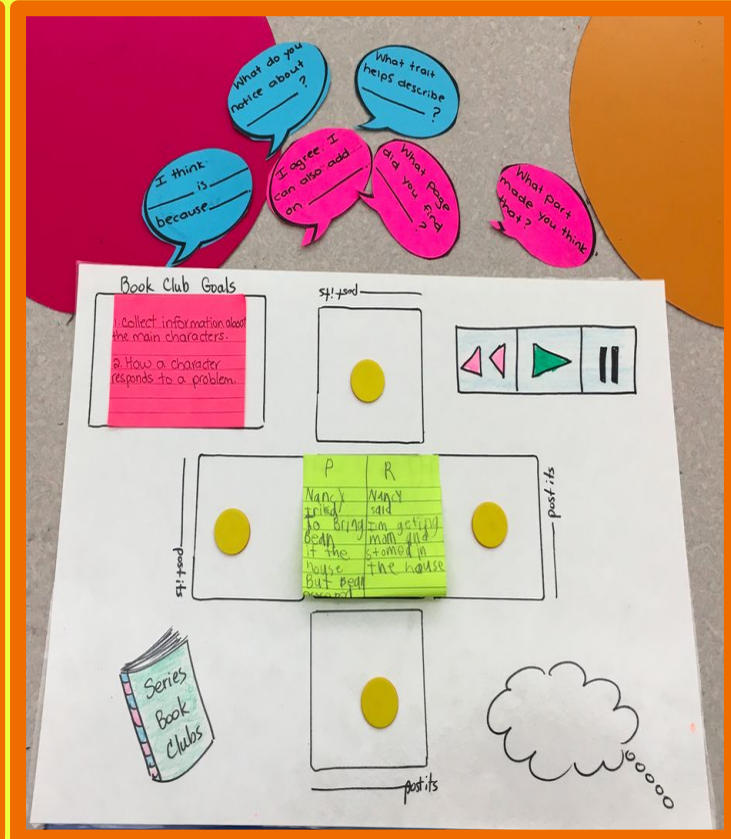
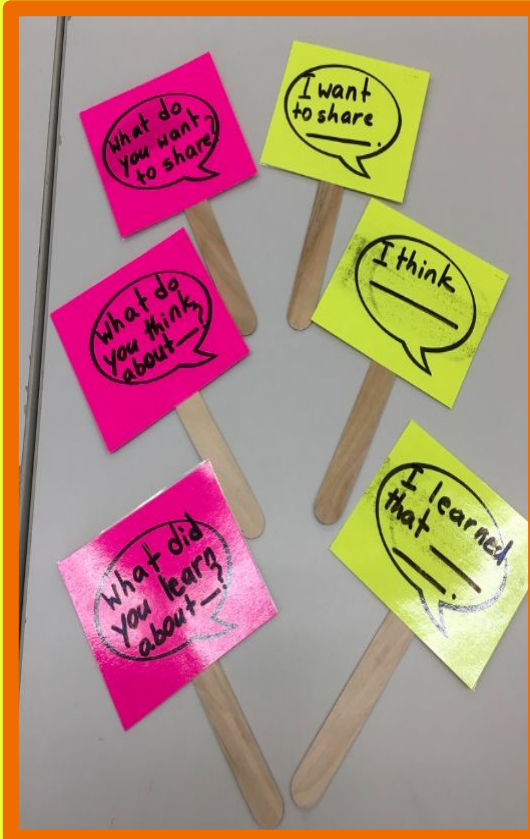
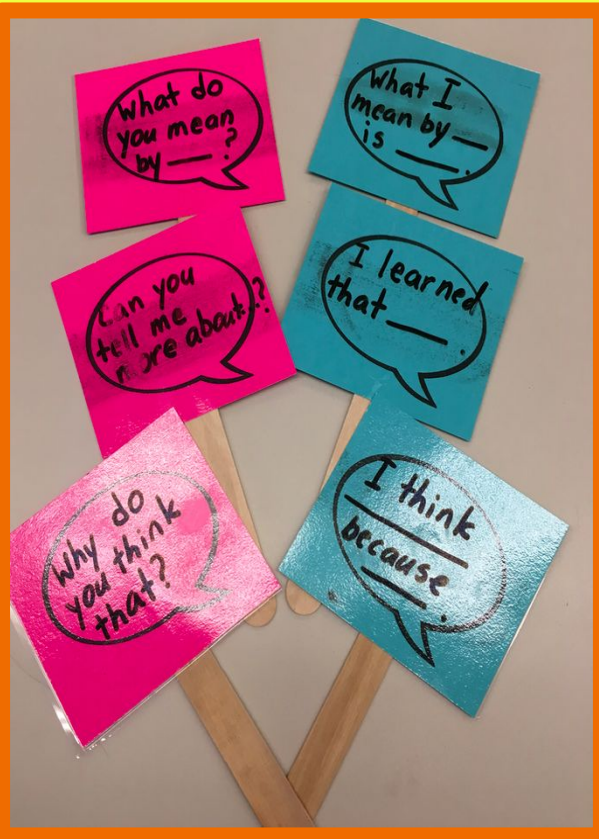

# Partnerships

Different variations:

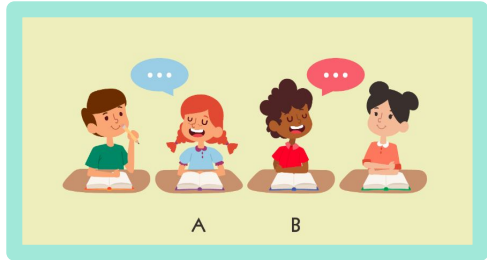

- Reading and writing partnerships
  - Math groups partnerships
  - Personality and proficiency match partnerships
  - Peanut Butter and Jelly Partners
  - Cookies and Milk Partners
  - Triads – Can be a very supportive configuration for lower levels ELLs
  - Book Clubs
  - Second Set Partners
-

# Partnership Examples

*From Mrs. Saracino's Class*



# Prompts

## Start with relatable, fun, engaging and authentic prompts

- Easiest way to practice conversation norms, active listening and new conversation skills
- Provide students a relatable venue and a feel for sustained and focused conversations
  - Most first and second graders were able to accomplish this in one to two lessons
- **Make sure** to consider different ideas and skills that YOUR students can share with one another
- **Make sure** your prompts are clear, focused and students have enough supports

## Transition to prompts that connect to the curriculum

- After students had the opportunity to practice beginner behaviors, active listening skills and back and forth conversations about every day topics.
- Provide opportunities and supports for using new language, content and thinking



# Starter Prompts

Every day relatable topics

## Family

- Tell about the people in your family.  
**Supports:** *Picture of the family*
- What do you together as a family?  
**Supports:** *Pictures of the activities*
- What is your favorite thing to do as a family or with anyone in your family?
- Tell about your favorite game, activity or toy?  
**Supports:** *Pictures, realia*

## Birthdays

- What birthday do you remember the most ?  
**Supports:** *Pictures, realia*
  - What was your favorite birthday dessert?  
**Supports:** *Pictures, realia*
  - What kind of birthday do you wish to have?  
**Supports:** *Pictures, realia*
-



# Starter Prompts

Everyday relatable topics

## School

- What was your favorite school activity last year?
- What school activity should we do this year?
- What is your favorite thing to do in our class?
- What is your favorite 100<sup>th</sup> day activity?
- What 100th day activity would you like to do?

## Seasonal

### Fall - Halloween

- What costumes have you worn in the past?
- What costume was your favorite?
- What is your favorite Halloween activity in school or at home?
- What is your favorite Halloween candy?
- Do you like Halloween?

### Winter - Winter Break

### Spring - Spring Break

### Summer - Summer Break

# Examples of Academic Prompts

LESS EFFECTIVE:	vs	MORE EFFECTIVE:
Discuss how you solved this math problem.		Work with your partner to come up with two ways to solve this problem. Ask each other “why” questions as you talk to explain why you are choosing to do certain things. For example.....
Describe the polar bear to each other.		How do adaptations help the polar bear survive in its habitat? You can use sentences like “If a polar bear didn’t _____ it probably wouldn’t survive because...”
In your conversation talk about your books...		What interesting parts or words do you want to share with your partner. You can use sentences like “I want to share ____ What do you notice on this page?”

# Classroom Application

Mrs. Saracino's Class

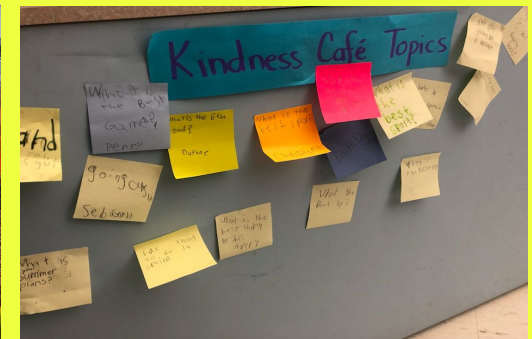
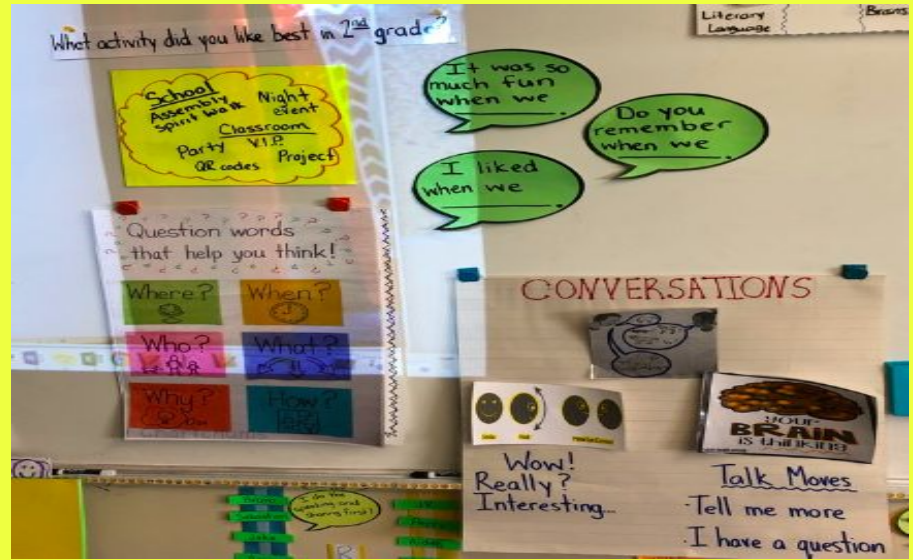
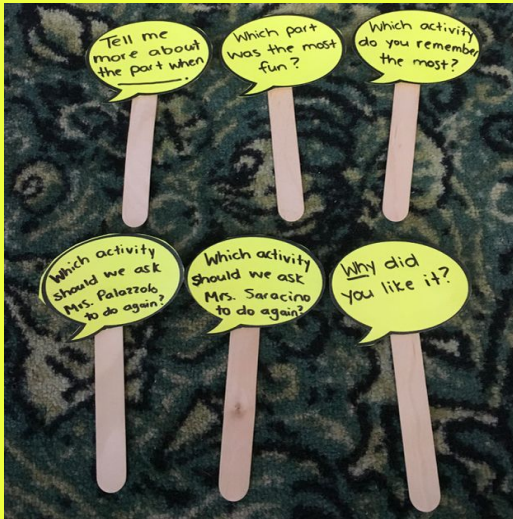

Kindness Cafe in Prep for Book Clubs  
Kindness Cafe - Prep for the Opinion Writing

# Classroom Application

Ms. D'Onofrio's Class

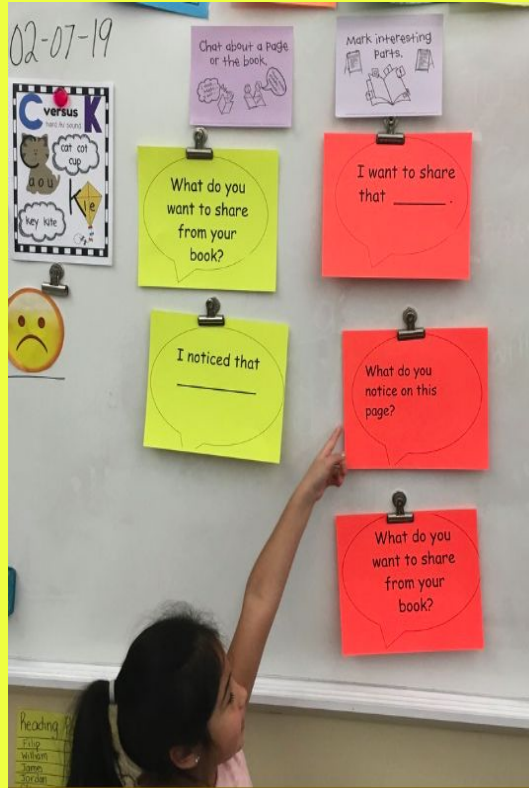

First Grade – Readers Workshop – Marking and sharing interesting parts

# Classroom Application

Mrs. Lustik's Class

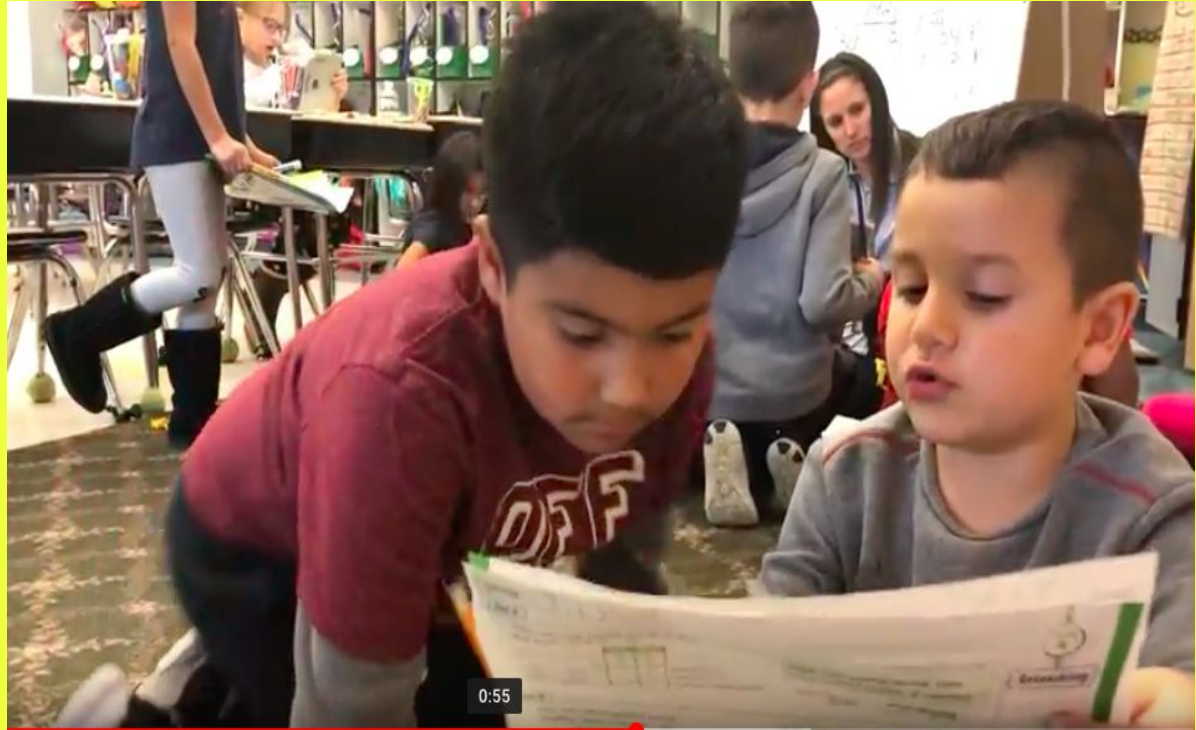

AC – 2<sup>nd</sup> grade Independent Practice in Math



# Classroom Application

Mrs. Saracino's Class

Collect information about the main characters

Frog and Toad are best friends.

Toad doesn't like to clean.

Frog and Toad like to spend their days together.

© 2013 by Heinen and Lucy Calles et al., Units of Study for Teaching Reading, Grade 2 Unit 4, Series Book Cluster, "Series Readers Become Experts on Characters" #1

I think \_\_\_\_\_ is \_\_\_\_\_ because \_\_\_\_\_.

What do you notice about \_\_\_\_\_?

What trait helps describe \_\_\_\_\_?

I agree, I can also add \_\_\_\_\_ on \_\_\_\_\_.

What page did you find \_\_\_\_\_?

What part made you think \_\_\_\_\_ that?

# Let's Practice!

Round 1 Prompt:

What are the benefits of incorporating conversations into your lessons?

Both partners think about the benefits as well as their experiences with this practice and jot the ideas for the conversation.



# What are the benefits of incorporating conversation into your lessons?

**Partner A:** Answer the question in the prompt and say as much or as little as you feel comfortable.

- I think incorporating conversations into the school day is important because...
- For example in my classroom I saw that...
- I also think...
- Many people might think that...
- Another reason...
- What are your thoughts about this topic?

**Partner B:** Practice Physical and Cognitive Indicators of listening while your partner is sharing. Response options either during or after Partner A shares:

- “Oh really. “Wow!” “Interesting!”, “Uh huh”, “Hmm..”
- Am I right in hearing you say that....?
- Can you please tell me more about...?
- I have a question about...
- Can you give an example from your classroom?
- I had a similar experience when...
- I had a different experience when...

# Now, let's add another layer...

Round 2:

Read: “The Benefits of Conversing in School” and denote ideas or concepts (+) you want to discuss in response to the question:

Prompt: What do you think about the idea of incorporating more opportunities for academic conversations into the school day?

# What do you think about the idea of incorporating more academic conversation into the school day?

**Partner B:** Starts the conversation by answering the prompt. Below are some possible ways:

- Students should have more academic conversation opportunities during the day because...
- In the article the author discusses.....
- Another reason...
- In my classroom I noticed...
- After this reading this article I think...
- What are your thoughts on this topic?

**Partner A:** Practice active and focused listening. Use the following response options:

- “Oh really...” “Wow!” “Interesting!”  
“Uh huh...” “Hmm...”
- I would love to hear more about...?
- So are you saying that....?
- I want to expand on your point about...

# **Excellence and Equity in Mathematics Instruction**

# Math Workshop

- Format for teaching math class practiced and widely supported within our district.
- Involves personalized, differentiated learning so that all students are able to learn, practice and find success within their level
- Supported by research, success in action

How does this  
promote equity  
& excellence?

# What does it look like?

## Elements:

- Number Sense Warm-up
- Minilesson
- Rotations: Practice, fluency, problem solving, number sense
- Teacher Station (or teacher conferring)
- Closing

## Options:

- Rotations
- Self-Guided
- Differentiation



# Number Sense Warm Up

Students are exposed to all levels of mathematical ability in a short, actively engaging warm up.

This is another type of “low floor/high ceiling” activity. It is quick and fun, but provides plenty of opportunity for mathematical discourse.

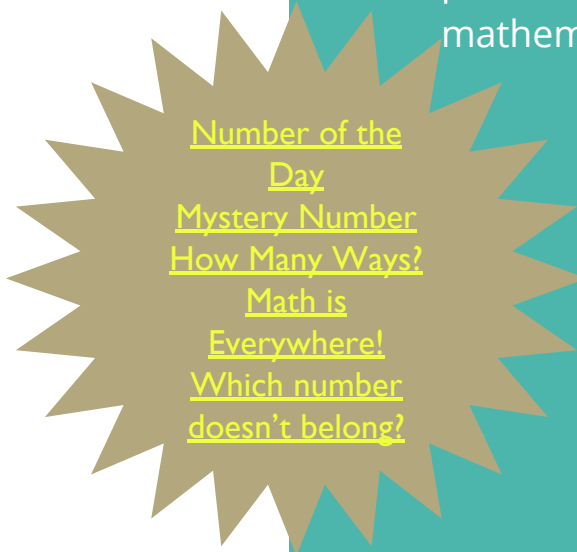

Number of the Day  
Mystery Number  
How Many Ways?  
Math is Everywhere!  
Which number doesn't belong?

# Number Sense Examples

## Number Sense Warm-Up: How Many Ways?

In this activity students are given a number (I usually pick the day, the month, how old I am, the number of days we've been in school, etc...make it meaningful and it's automatically more engaging!) and a time limit to list as many ways to make the number possible. When played multiple times and more responses are shared, students begin to see equations differently and learn different ways to decompose numbers.

This example is a first grader, the first time he tried this activity with a time limit of 2 minutes.

$93$   
 $1 \times 12$   
 $8 + 4$   
 $2 = 0$   
 $10 + 2$   
 $1 + 1 + 1$   
 $2 + 10$   
 $0 + 2$

## WHAT THE TEACHER NOTICED!

### Number Sense Warm-Up: Math is Everywhere!

In this activity, students are shown a photograph and given a time limit to find as many different math concepts as possible. Students then share, typically by sharing the part of the picture where they found math and explaining their thinking. This is an instantly differentiated activity—students will show what they know and can be successful at finding math at any level. Here, I shared my own findings after we discussed theirs.

This can be made more engaging/personalized by the teacher using pictures from the school or community, their own family photos, or having students bring in pictures to use.

There are squares lined up in arrays.

Based on the student's clothes, I estimate it is about 45 degrees outside.

The window is broken up into 4 parts.  $\frac{2}{4}$  of the window is covered with a shade.

The word Howell has 6 letters. The word Township has 8 letters. Adelphi has 8 letters. School has 6 letters.  $6 + 8 + 8 + 6 = 28$  letters in all

The number 495 has 4 hundreds 9 tens and 5 ones.

There are 4 rows of 5, so there are 20 in all.  $4 \times 5 = 20$

I see one student.

Since the building is symmetrical, there are also 20 squares on this side.  $20 + 20 = 40$  or  $20 \times 2 = 40!$

There are 0 school buses in front of the school!

There are 5 diagonal lines in the street.

# Number Sense Examples

• Not over 40  
 • Not less than 10  
 • Bigger than 20  
 • Bigger than 30  
 • Even Number  
 • Does not have a 4 in its ones place

**Number Sense Warm-Up: Mystery Number**

This example was done in a second grade classroom. I gave the students hundreds charts inside wipe off sheet protectors, so they could eliminate numbers on the chart as the clues were revealed.

The students asked yes or no questions to try and guess the number within 20 questions, and eventually set a goal for less questions.

The "Mystery Number" paper on the board has the number underneath to be revealed after the students have guessed.

After playing this for a while, students will see different examples of the types of questions to ask in order to get the number more quickly. You could have student volunteers run the activity once you've played a few times.

You could make this more challenging by using larger numbers, including exponents, eliminating the hundreds chart as a tool. It could be scaffolded by lessening the number range or providing clues.

**Number Sense Warm-Up: Number of the Day**

In this activity, we choose a number of the day as a group. Make it meaningful! Pick a kid to choose a number that means something. Then, depending on the age and time parameters, either have kids choose certain hexagons, assign differentiated questions, or let them try to complete the whole page. These promote excellent conversation! My personal favorites are "when is this a lot/when is this a little?" Really builds their conceptual understanding of what quantities are and how they are related.

8

Write it in words  
eight

When is it a little?  
8 minutes  
8 seconds  
\*

When is it a lot?  
8 years  
hours  
\* days (depends!)

Use 3 addends to make the number:  
 $0+0+8$   
 $4+4+0$   
 $2+2+4$   
 $7+1+0$

How close is the number to your age?  
2 years  
1 year

Use 6 addends to make the number:  
 $1+1+1+1+2+2$

Double it!  
 $8+8=$   
16

When is half the number?  
4

How many are in 10 groups of the number?  
8

(6)  
(1)

The minilesson is a short, 10-15 minute lesson where the teacher directly instructs the class using examples. During the minilesson, there are many opportunities for students to share meaningful discourse regarding the mathematical concepts being presented.

# Minilesson

---

# Rotations

Students spend time rotating through differentiated stations. Typically, they first practice what they learned with independent practice. Then, they work on fluency, problem solving, and number sense with a variety of meaningful activities at their level.

---

Teachers keep careful records and pre-assess their students to determine the best grouping for math workshop. During the teacher station, teachers either use a scaffolded approach to instruction (manipulatives, models, organizers, etc) or stretch student thinking with challenging activities related to the class math goal for the day.

# Teacher Station

---

# Closing

Students come back together to reflect on the work they've done and what they've learned. This is another excellent opportunity for mathematical discourse.

---



# Low Floor, High Ceiling

- By designing activities that are engaging, mentally stimulating, and accessible to all learners, equity and excellence will certainly exist within your instructional practice.
- “Low floor, high ceiling” refers to activities that all learners can engage in regardless of specific ability level.
- Strategic questioning on the part of the teacher can help support these types of activities.
  - Mathematical Practices: Questions to Develop Mathematical Thinking

# Example: 3 Act Math

## Act 1:

Introduce an inquiry-based problem.

What do you notice?

What do you wonder?

Help students to create a **range of estimates** with their actual estimate included.

What information is needed to solve?

## Act 2:

Give students more information to help them solve.

**Support the productive struggle!**

Students solve by any method that makes sense to them.

Perfect place to question students and promote academic conversation.

## Act 3:

Answer is revealed, usually through video.

Another great opportunity for conversation!

Discuss where the students' answers fell within their ranges

Incorporate **mathematical practices** students used to solve the problems.

# Mathematical Discourse

MATHEMATICS

Is not about  
numbers,  
equations,  
computations, or  
algorithms:  
it is about

UNDERSTANDING.

*William Paul Thurston*

# Math Conversation: Establishing Norms

## Math Talk Expectations

In our learning community, we...

1. are all learners who make sense of math.
2. treat each other with respect.
3. keep trying even when the problems are hard.
4. participate and show others we are listening.
5. can make mistakes and revise our thinking.
6. share our ideas and ask good questions.

$4 \times 5 = 20$   $4 \times 5 = 20$

Do you agree? 

ROUTTY

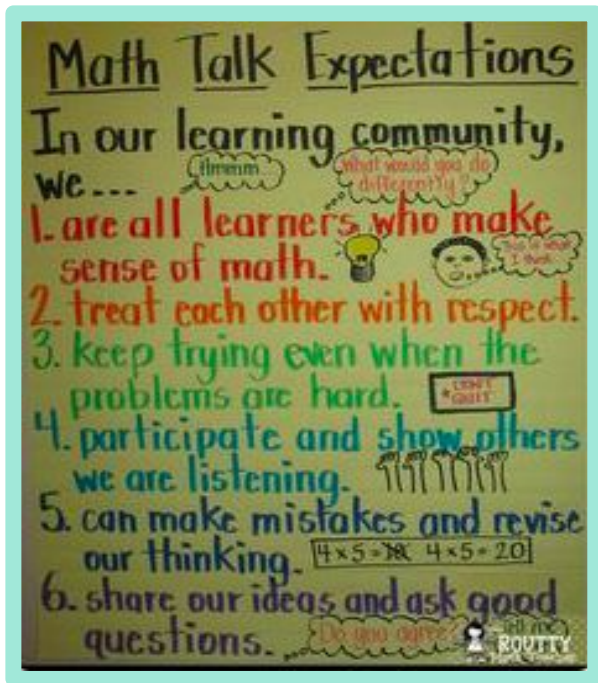

## Be a Good Math Partner

1. Work side by side.
2. Both people should be on the same problem.
3. Agree & disagree respectfully.
4. Explain your thinking to your partner.
5. Speak in a volume that only your partner can hear you.

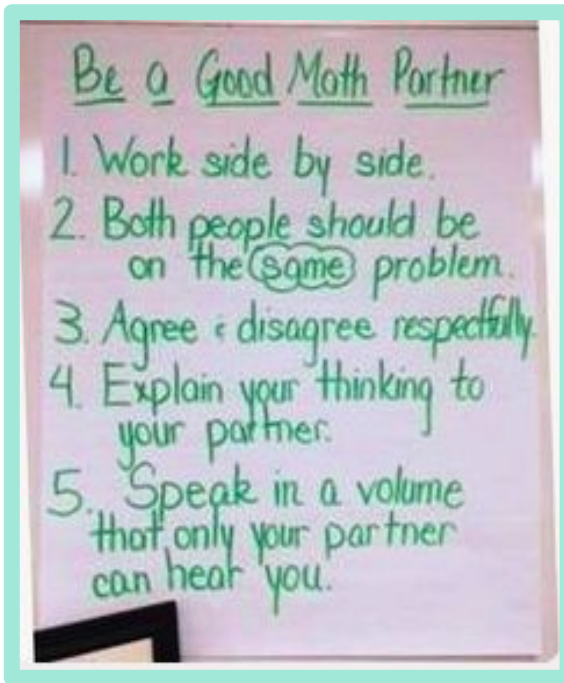

## Math Norms

1. Explain your brain!
2. Ask questions
3. Agree or Disagree Nicely!
4. Use Accountable talk
5. Participate!

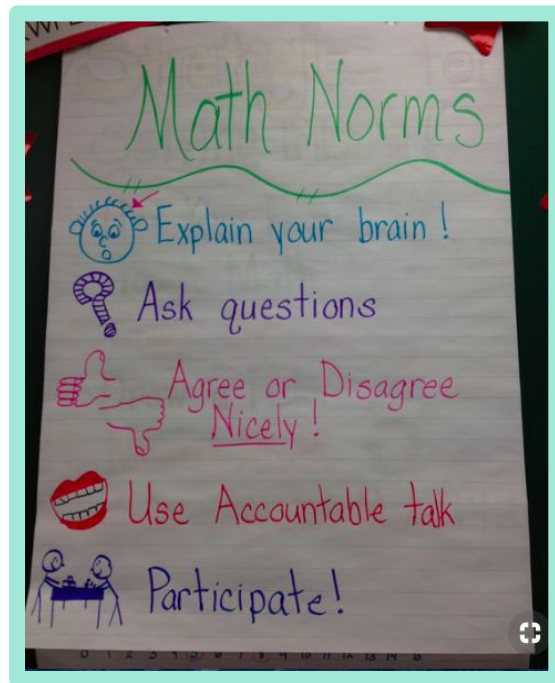

# Mathematical Discourse to Understand Mathematical Ideas and Utilize Mathematical Practices

## What are teachers doing?

Engaging students in purposeful sharing of ideas, reasoning, and approaches, using varied representations

Selecting approaches and solution strategies for whole-class analysis and discussion

Facilitating discourse among students by positioning them as authors of ideas, who explain and defend their approaches

Ensuring progress toward mathematical goals by making explicit connections to student approaches

*NCTM, 2013*

## What are students doing?

Presenting and explaining ideas, reasoning, and representations to one another in pair, small group, and whole class discourse

Listening carefully to and critiquing the reasoning of peers, using examples to support or counterexamples to refute arguments.

Seeking to understand the approaches used by peers by asking clarifying questions, trying out strategies, and describing approaches used by others.

Identifying how different approaches to solving a task are the same and different.

# Practices for Orchestrating Productive Math Discussions

**Anticipating** students' solutions to a mathematical task

**Monitoring** students' in-class, "real time" work on the task

**Selecting** approaches and students to share them

**Sequencing** students' presentations purposefully

**Connecting** students' approaches and the underlying mathematics

# Conferring



- The practice of talking with students as they engage in meaningful work with the purpose of uncovering their thinking and supporting learning in the moment.
- Allows for scaffolding practices with each student and makes learning accessible.

Heinemann and Stanford Education, 2016

Gerardo's book has 634 pages. So far he has read 379 pages. How many more pages does Gerardo need to read to finish his book?

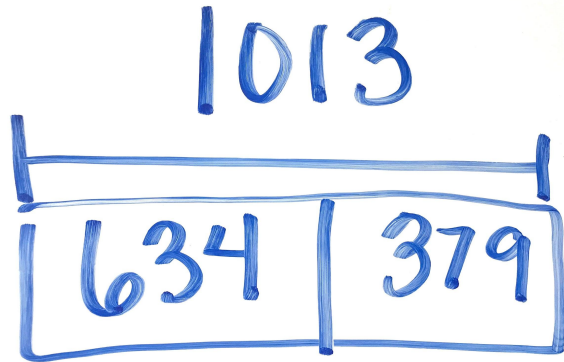

## Your turn:

- Turn and talk to a peer.
- Analyze student work.
- Discuss which questions from the *100 Questions that Promote Mathematical Discourse* handout would be best for conferring with this student.



# Providing Feedback

Establishing effective math discourse routines and engaging in conferring in mathematics will provide teachers the ability to:

- shift feedback from just procedural to meaningful, effective and personal
- feedback becomes grounded in evidence

Conferring with students provides the student with a safe, comfortable setting to express their thinking and ideas

These opportunities are invaluable to the teacher and the student, building relationships that foster positive learning outcomes, equity and excellence for all learners.

# My Next Steps

I am not ready **yet**...

- I need to observe others trying.
- I would like to try with someone.
- I need to see more examples.
- I want to read about it on my own.
- I want to plan with another teacher.
- I need/want to...

I am **not** sure...

I need some more time to think about this before I decide on my next steps.

**Yes**, I am ready!

- My class needs to start with the behaviors.
- My class needs to start with active and focused listening.
- My class needs to start with academic conversation skills.

# EQUITY

- *What does it mean to have equitable opportunities within a guaranteed and viable curriculum?*
- *How might more equitable opportunities advance student learning and educator practice?*
- *Would you now enhance or amend your earlier thoughts?*

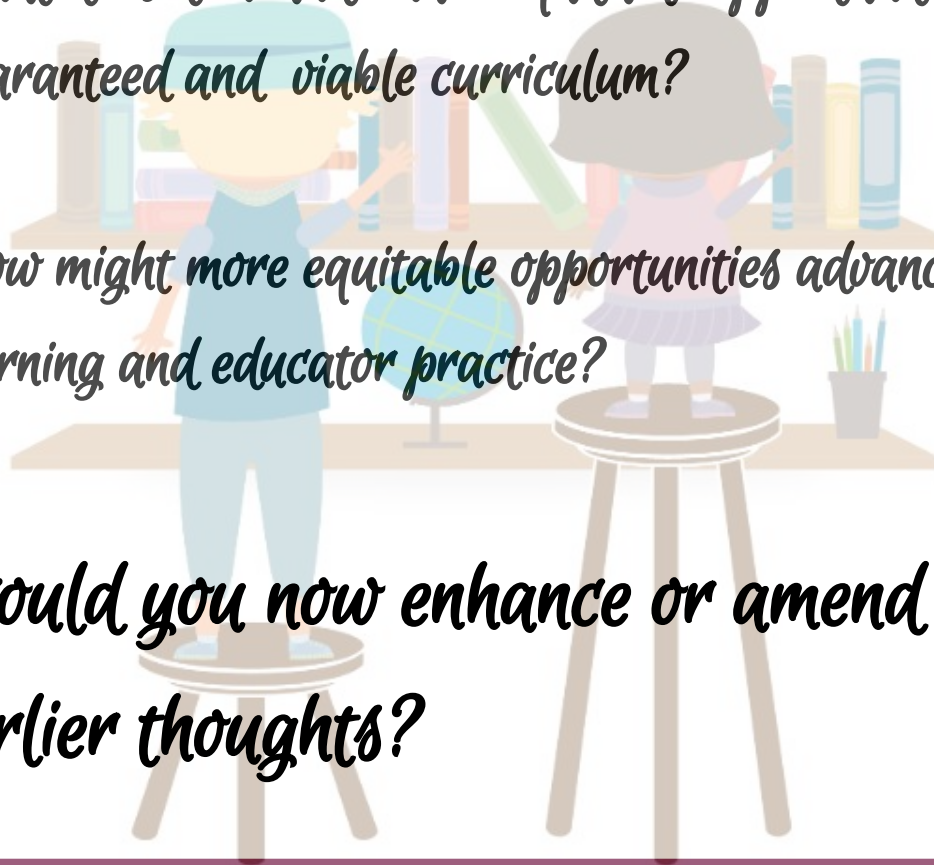

## Tools 3-6: Electronic Tools

Links that provide helpful information when choosing and evaluating materials to support district curricula.



<https://www.edreports.org/>



<https://www.evidenceforessa.org/>



<https://ies.ed.gov/ncee/wwc/>



<https://www.achieve.org/our-initiatives/equip/equip>

# Wrapping Up

Take a moment to finish your notes!

- Add final touches to your sketch notes based on what you learned, or
- Complete any empty squares on your die, cut it out and glue/tape together, or
- Complete your notes in another note taking form you chose.

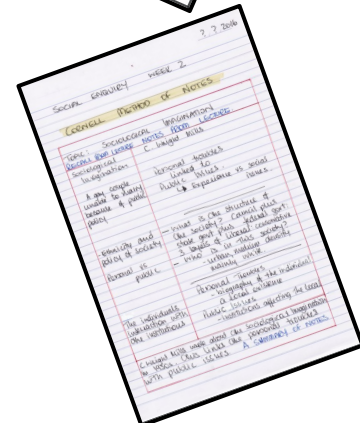
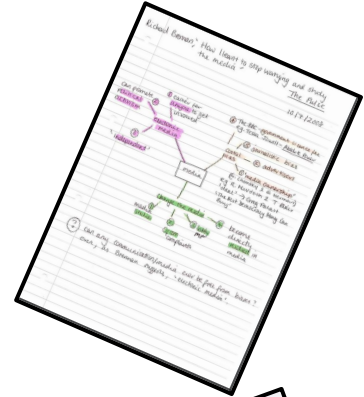
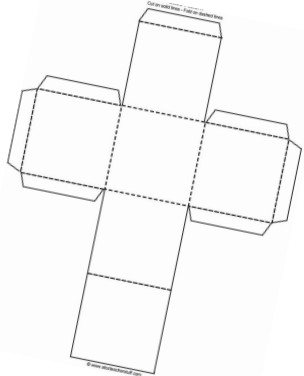

# Wrapping Up

## Share What You Learned!

- Show your table group your sketchnotes and explain one drawing, or
- Role your die and explain the notes you took on the side that is facing up, or
- Come up with another creative way to share what you learned!

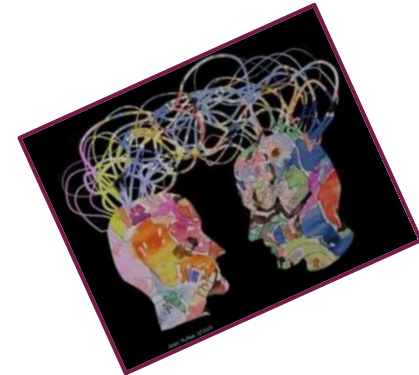
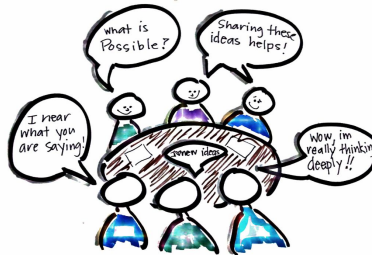
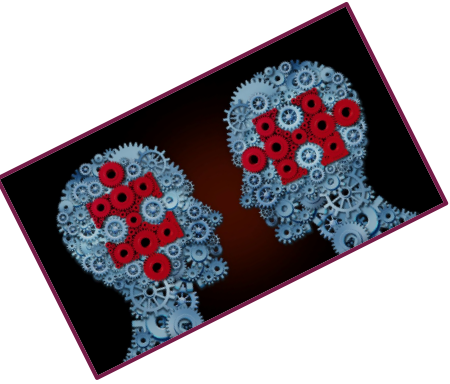

# Stay connected with



- Web:



<https://nj.learningforward.org/>

- Facebook:



[https://www.facebook.com/LearningForwardNewJersey/?ref=page\\_internal/](https://www.facebook.com/LearningForwardNewJersey/?ref=page_internal/)

- Twitter:



[@LearnForwardNJ](#)



SAFE  
TRAVELS

THANK  
YOU

FOR  
COMING